

Q: How to recover N.power's firmware?

A: Please refer the steps to restore your N.Power by using Emergency Upgrade:

1. Please connect the LAN Port2 to your PC directly.
2. Set your PC's IP address as 192.168.1.50, subnet mask as 255.255.255.0.
3. Before connecting the power, please press and holding the "Reset" button (in the back of the AP). Then plug in the power. Keep press and hold the Reset button until the LED of the selected port goes on(about 3 seconds).

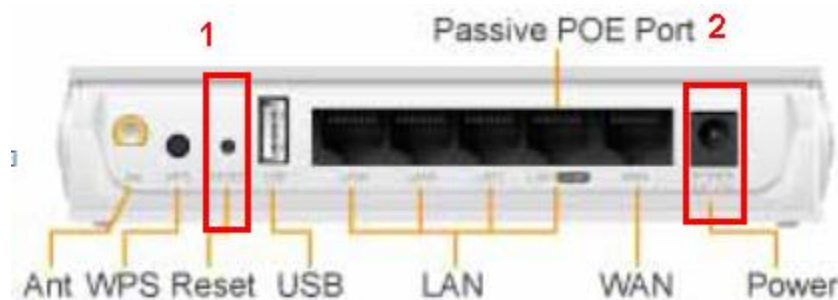

6. Open a browser; type "http://192.168.1.254" for the website address. The following screen should show up:

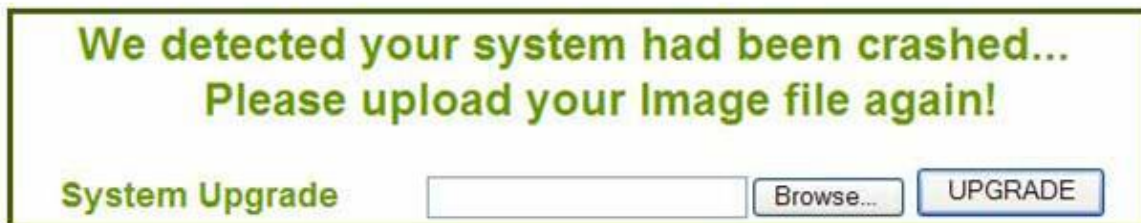

7. Click the "Browse" button, select and open the correct firmware file.

8. Click on "UPGRADE" button. Do not touch the AP or PC until the upgrade is completed.



9. After upgrading, the configuration will recover from the previous settings. Please access your device at previous IP address. If you forget what the previous IP address is or if you can't access the device, please push the reset button for 10 seconds to restore your AP to factory default settings. The system will reboot. Then, you should be able to login into the normal Web UI at the default IP: [http: //192.168.1.254](http://192.168.1.254) .